

# Data mining, machine learning, and uncertainty reasoning

林偉川

## Close neighborhood of machine learning

- The general label of **machine learning** is reserved for **artificial intelligence-related** techniques, especially for those whose objective is to **induce symbolic descriptions** that are **meaningful and understandable** and at the same time help **improve performance**
- In a broad understanding, the machine learning task can be defined as any **computational procedure** leading to an **increased knowledge or improved performance** of some process or skill such as **object recognition**

2

## Close neighborhood of machine learning

- Learn-to-recognize task is often addressed by methods that are not included in **machine-learning** paradigm but which have **the same or similar objective**
- **Traditional pattern recognition** and **statistical data analysis** are spawned many useful techniques
- 2 techniques must be mentioned because of their **popularity**, and because of the many attempts to combine them with machine-learning algorithms : **neural networks** and **genetic algorithms**

3

## The picture of **Biological Neuron**

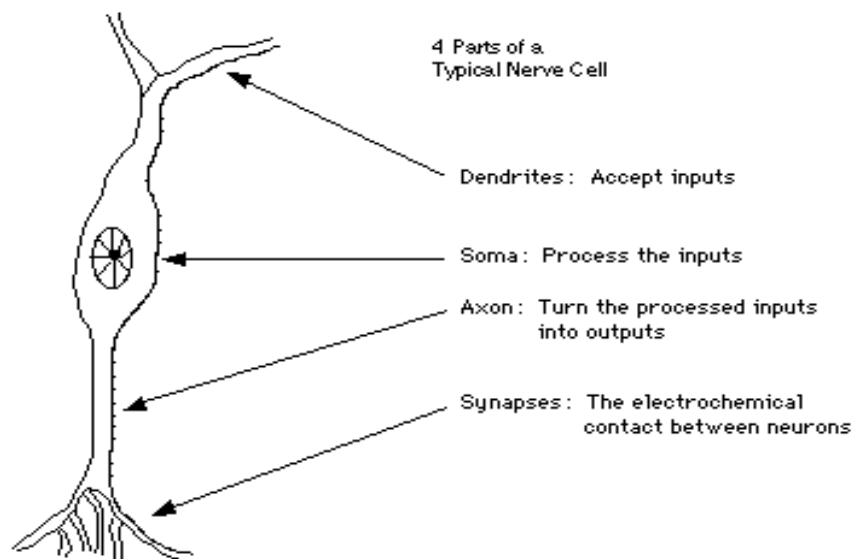

## The Biological Neuron

- All natural neurons have 4 basic components, which are **dendrites**(樹狀突), **soma**(體細胞), **axon**(神經細胞之軸索), and **synapses**(突觸). Basically, a biological neuron **receives inputs from other sources**, combines them in some way, performs a generally **nonlinear operation** on the result, and then **output the final result**.

5

## The Biological Neuron

- The most basic element of the human brain is a specific type of **cell**, which provides us with the abilities to **remember, think, and apply previous experiences** to our every **action**. These cells are known as **neurons**(神經元), each of these neurons can connect with up to 200000 other neurons. The power of the brain comes from the numbers of these basic components and **the multiple connections between them**.

6

## Biological Neuron Architecture

- The neuron has two important parts, called the **synapse** and the **dendrite**
- The **dendrites** are **extensions of a neuron** which connect to other neurons to form a neural network
- The **synapses** are a **gateway** which **connects to dendrites that come from other neurons**. A biological neuron may be connected to other neurons as well as accepting connections from other neurons

7

## Biological Neuron Architecture

- **Neuron receives information from other neurons**, processes it and then **relays this information to other neurons**
- Neuron **integrates the pulses** that arrive and when this integration **exceeds a certain limit**, it **emits a pulse**
- Dendrites **modify the amplitude of the pulses** travelling through Neurons. This modification varies with time, as the network **'learns'**

8

## The Analogy to the Brain

- The most basic components of **neural networks** are modeled after the structure of the **brain**. Some neural network structures are **not closely to the brain** and some does not have a **biological counterpart** in the brain. However, neural networks have a strong **similarity to the biological brain** and therefore a great deal of the terminology is borrowed from **neuroscience**.

9

## What is Neural network

- It is an attempt to **simulate within specialized hardware or sophisticated software**, the **multiple layers of simple processing elements** called **neurons**. Each neuron is linked to certain of its **neighbors** with **varying coefficients of connectivity** that represent the strengths of these connections. Learning is accomplished by **adjusting these strengths** to cause the overall network to output appropriate results.

10

## What is Neural network

- **Artificial Neural Network** is a system loosely modeled on the **human brain**. The field goes by many names, such as **connectionism, parallel distributed processing, neuro-computing, natural intelligent systems, machine learning algorithms,** and **artificial neural networks**.

11

## The Artificial Neuron

- The basic unit of neural networks, the artificial neurons, **simulates the 4 basic functions of natural neurons**. Artificial neurons are much simpler than the biological neuron

12

## Artificial neural network

- Mark Rosenblatt suggested to use for pattern-recognition application by a simple device inspired by **mathematical models** of biological neurons
- He dubbed this device a **perceptron**, and showed how it can be **trained** for the recognition job simply by **automatic adjustments of its parameters**, based on a set of **pre-classified examples**

13

## General scheme of perceptron

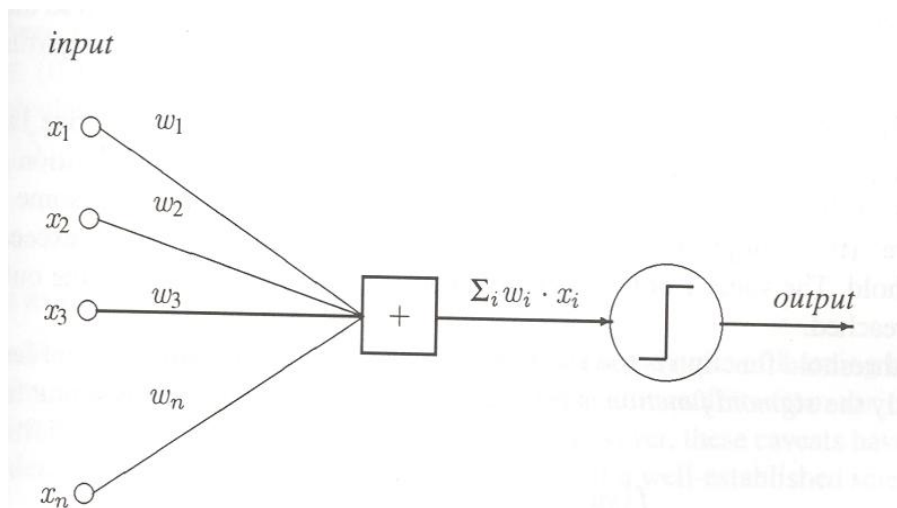

14

# The picture of Artificial Neuron

$$I = \sum w_i x_i \text{ Summation}$$

$$Y = f(I) \text{ Transfer}$$

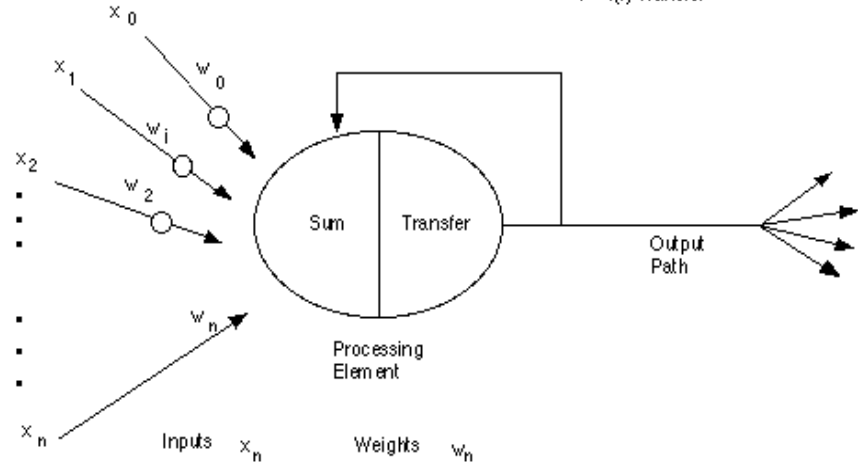

15

# Basic neuron model

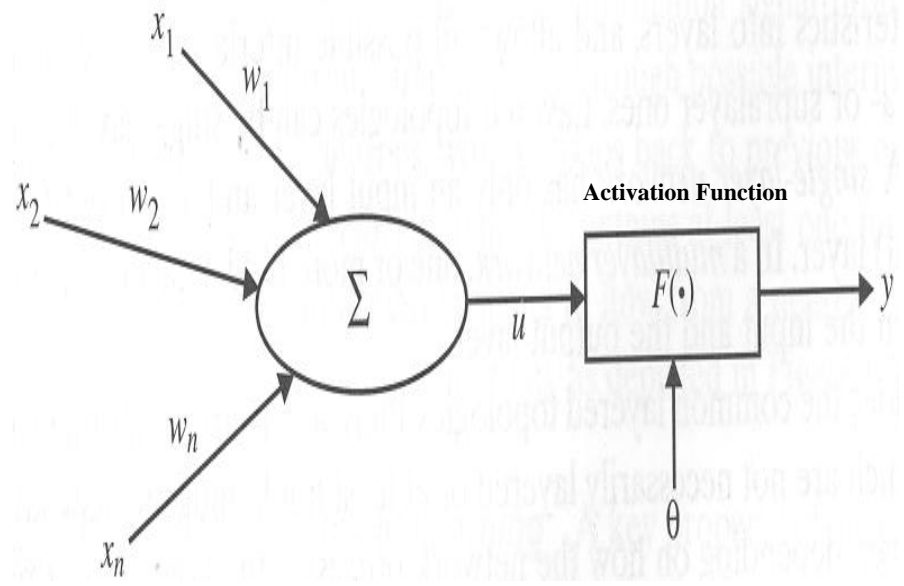



## Artificial neural network

- Several **input signals**,  $x_i$ , each multiplied by a **weight**  $w_i$ , are attached to a **summation unit**
- The resulting sum is subjected to a **step function** ensuring that if the sum exceeds **a certain threshold**  $\Theta$ , the output of the **perceptron** is **1**, otherwise the output is **0**. as an alternative to the value 1 and 0, any other pair of outputs can be considered, say **1, -1**

$$sum = \sum_i x_i \bullet w_i$$

17

## Artificial neural network

- Proper adjustments of the weights  $w_i$  and of the threshold  $\Theta$  ensure that the perceptron will **react to input vectors with the required output value**
- The information is **encoded in the weights** assigned to each individual input, each input representing an **attribute**
- **More relevant** attributes are assigned **more weight** and **less relevant** attributes have **less weight**

18

## Artificial neural network

- Perceptron's learning algorithm seeks such **weight values** that will accomplish the requested mapping from **the space of input vectors** to the set of **2 binary values**,  $\mathbb{R}^n \rightarrow \{0,1\}$  or  $\{1, -1\}$
- Some concepts cannot be acquired by the perceptron. That is why perceptrons are rarely used in **isolation**
- They are interconnected in structures such as the **multilayer perceptron**

19

## Neural network -- XOR signal

- The multilayer perceptron consists of one layer of **input nodes**, **output nodes**, and **one or more 'hidden' layer** between them
- During the recognition phase, the components of the **input vectors** are clamped to the input layer
- Each **neuron** is represented by a McCulloch-Pitts model, which uses a **threshold function** for its activation function
- Bit 0 and 1 are represented by the levels 0 and +1

20

## XOR signal flow graph

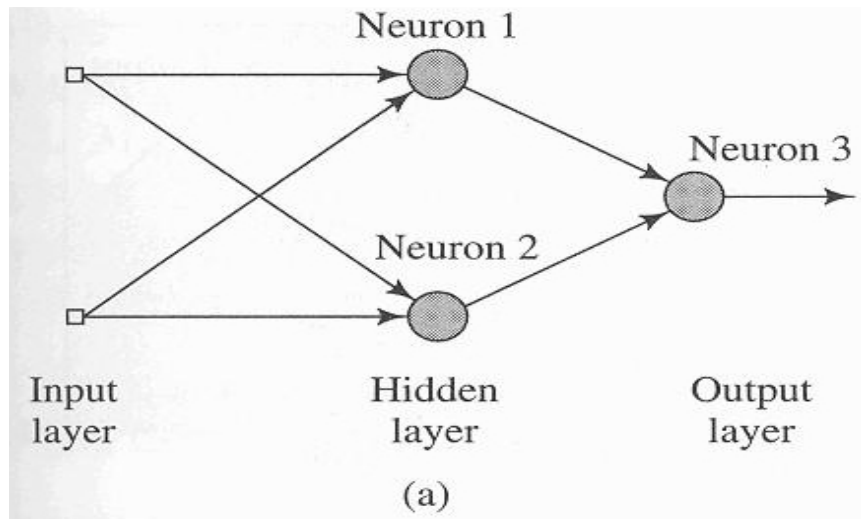

## XOR signal flow graph

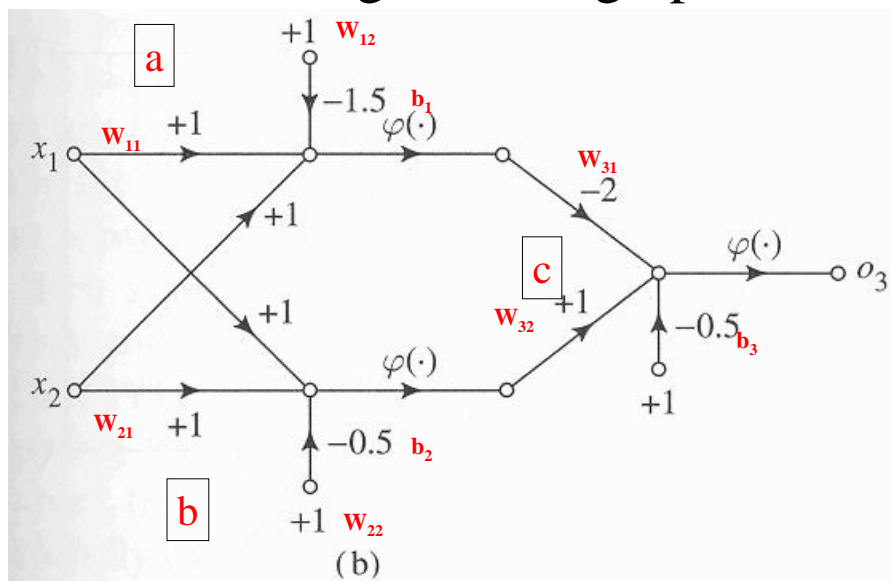

### Decision boundary by upper neuron 1

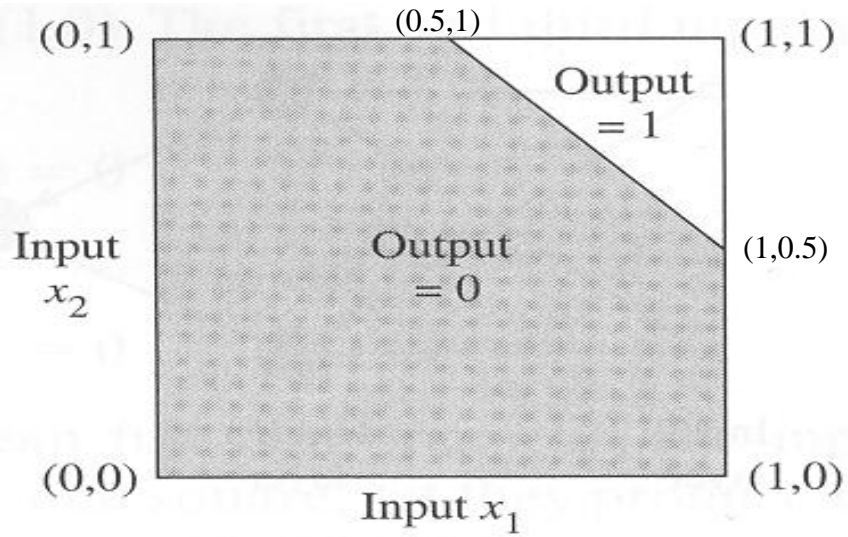

(a)

### Decision boundary by upper neuron 2

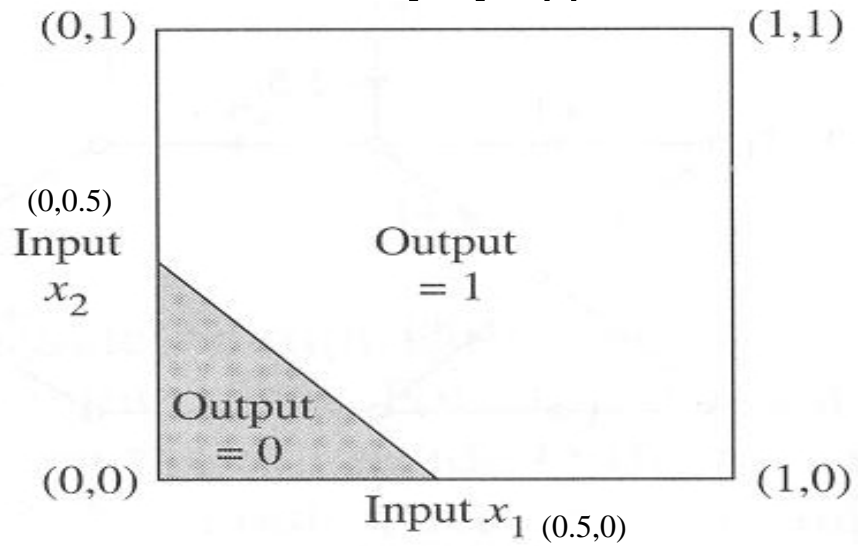

(b)

### Decision boundary by upper neuron 3

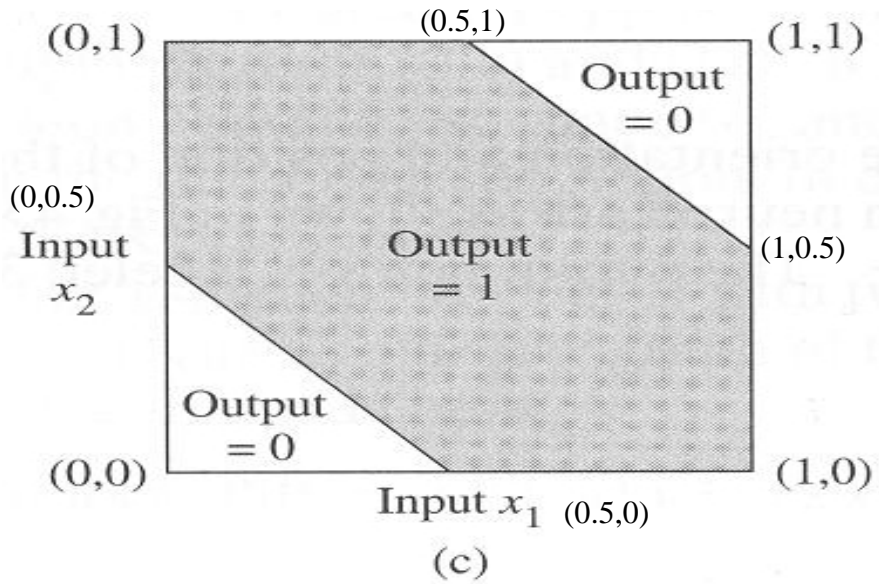

### XOR

X	Y	X XOR Y
0	0	0
0	1	1
1	0	1
1	1	0

## Neural network

- Some of the **perceptrons** 'fire' (their output is 1), when the **weighted sum of their inputs** exceeds the particular **threshold**
- The value 1 or 0 is **propagated to the next layer**, until the output of the network is reached
- As the basic threshold function is too rigid (**it does not tolerate noise and does not facilitate learning**), usually the **sigmode function** is used to calculate the output of a **single unit from its inputs**:

$$f(\text{sum}) = \frac{1}{1 + e^{-\text{sum}}}$$

sum is the **weighted sum** of the signals at the input unit

27

## Sigmode function of output

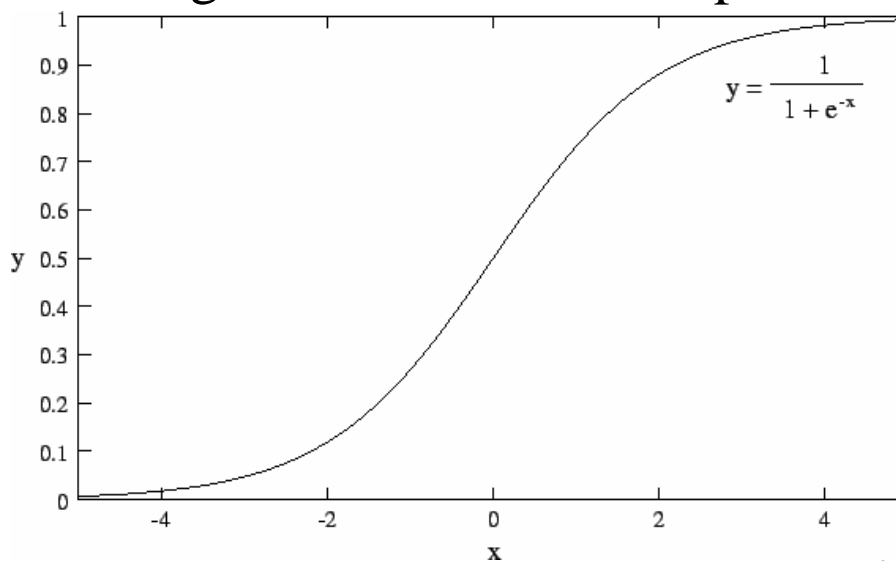

## Neural network

- According to the previous formula, the unit will output a real value between **0 and 1**
- For sum=0, the output is **0.5**. For **large negative values** of sum the output converges to **0**. For **large positive values** of sum the output converges to **1**
- The formula is more tolerant than the step function with respect to **noisy signals**
- In many complicated tasks, the **hidden layer** may be used **2 or more layers**

29

## Examples of Activation functions

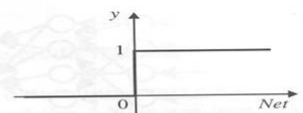
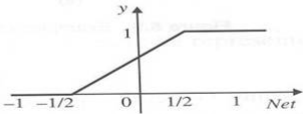
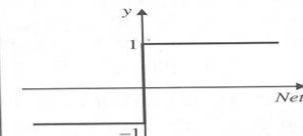
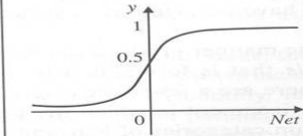
<b>Threshold</b>	$y = F(Net) = \begin{cases} 1 & Net \geq 0 \\ 0 & \text{otherwise} \end{cases}$	
<b>Piecewise Linear</b>	$y = F(Net) = \begin{cases} 1 & Net \geq 0 \\ 0 & Net \leq \frac{1}{2} \\ Net & -\frac{1}{2} < Net < \frac{1}{2} \end{cases}$	
<b>Hard-Limiter</b>	$y = F(Net) = \begin{cases} 1 & Net \geq 0 \\ -1 & Net < 0 \end{cases}$	
<b>Sigmoid (Logistic)</b>	$y = F(Net) = \frac{1}{1 + e^{-Net}} \quad y \in (0,1)$	

## Neural network architecture

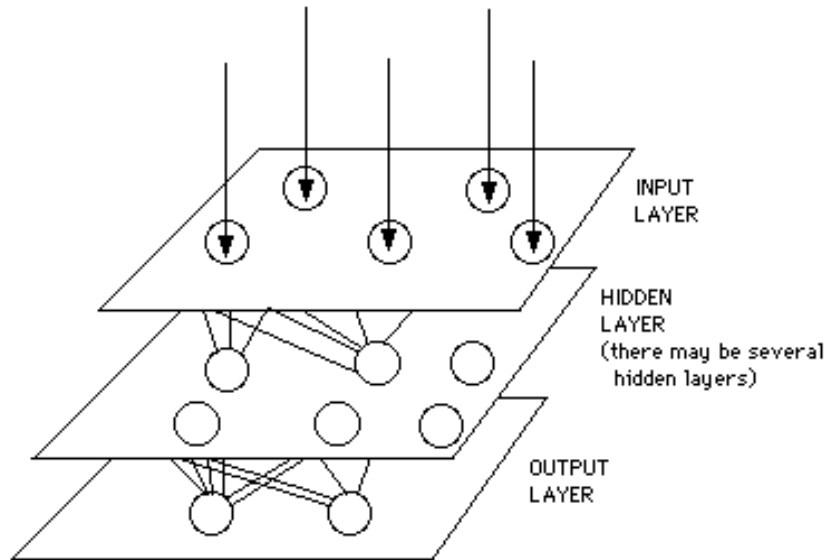

## Multilayer perceptron

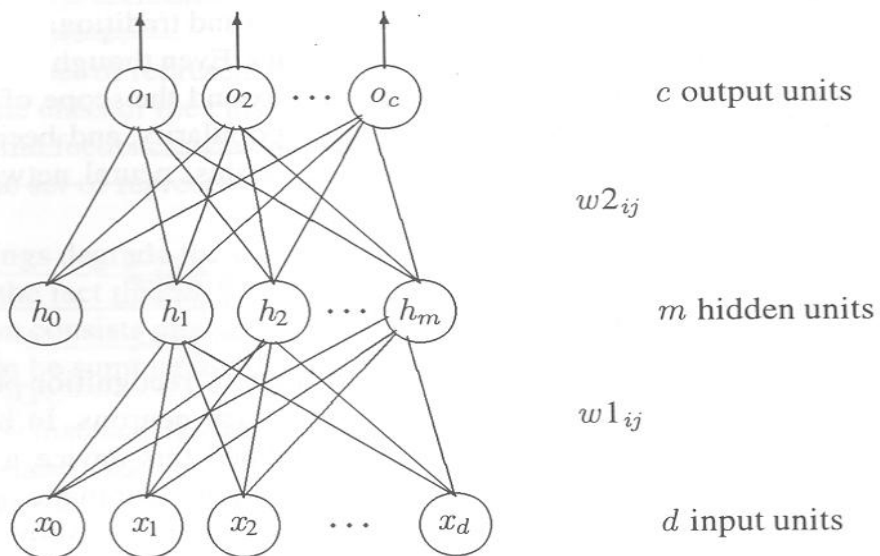



## The design of neural network

- The developer must go through a period of **trial and error** in the design decisions before coming up with a satisfactory design. **The design issues in neural networks are complex** and are the major concerns of system developers.
- The process of designing a neural network is an **iterative process**

33

## The design of neural network

- **Designing a neural network consist of:**
  - Arranging **neurons** in various layers
  - Deciding the type of **connections** among neurons for **different layers**, as well as among the neurons within a layer
  - Deciding the way **a neuron receives input and produces output**
  - Determining the **strength** (weight) of connection within the network by allowing the **network learn** the **appropriate values** of connection weights by using a **training data set**

34

## Interlayer connection

- There are different types of **connections** used between layers, these connections between layers are called **inter-layer connections**.
  - **Fully connected**  
Each neuron on the **first layer is connected to every neuron on the second layer**.
  - **Partially connected**  
A neuron of the first layer does not have to be connected to all neurons on the second layer.

35

### Interlayer connection– Fully connected

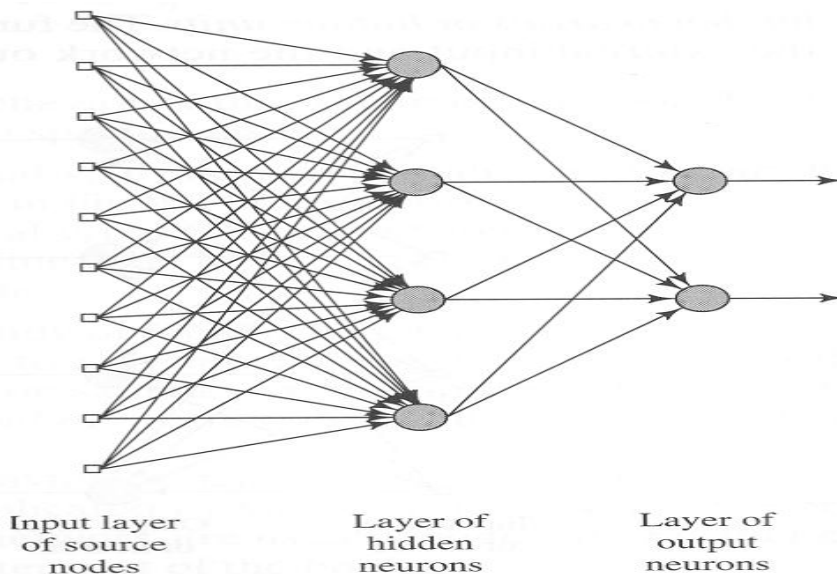

## Interlayer connection

- **Feed forward**

The neurons on the **first layer send their output to the neurons on the second layer**, but **they do not receive any input back** from the neurons on the second layer.

- **Bi-directional**

There is another set of connections carrying the output of the neurons of the second layer into the neurons of the first layer. **Feed forward and bi-directional connections** could be **fully- or partially** connected.

37

## Interlayer connection– Feed Forward

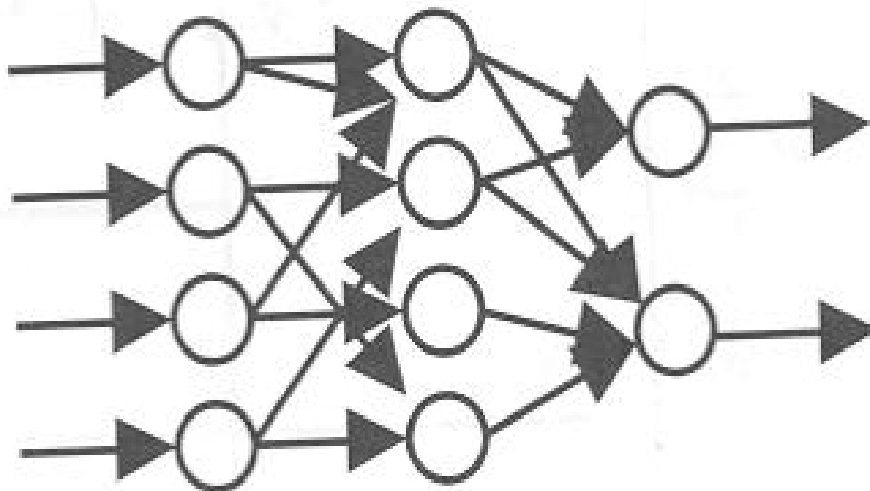

## Interlayer connection

- **Hierarchical**

If a neural network has a **hierarchical structure**, the neurons of a **lower layer may only communicate with neurons on the next level** of layer.

- **Resonance(共鳴)**

The layers have **bi-directional connections**, and they can continue sending messages across the connections a number of times until a certain condition is achieved.

39

## Intra-layer connection

- In more complex structures the neurons communicate among themselves **within a layer**, this is known as **intra-layer connections**. There are two types of intra-layer connections such as **Recurrent, On-center/off surround** connection

40

## Intra-layer connection (**Recurrent**)

### – **Recurrent** (週期性)

The neurons within a layer are fully- or partially connected to one another. After these neurons receive input from another layer, they **communicate their outputs with one another a number of times before they are allowed to send their outputs to another layer**. Generally **some conditions** among the neurons of the layer **should be achieved** before they **communicate their outputs** to another layer.

41

## Intra-layer connection (**Recurrent**)

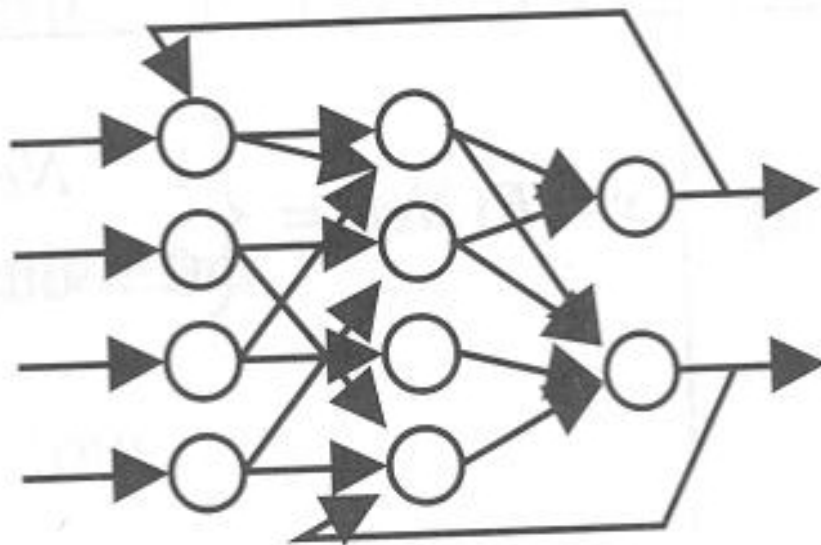

12

## Intra-layer connection (**Recurrent**)

- There are two types of connections between two neurons, **excitatory** or **inhibitory**.
- In the **excitatory connection**, the output of one neuron **increases the action potential of the neuron** to which it is connected.

43

## Intra-layer connection (**Recurrent**)

- When the connection type between two neurons is **inhibitory**, the output of the neuron sending a message would **reduce the activity or action potential of the receiving neuron**.
- **Excitatory connection** causes the summing mechanism of the next neuron to **add** while the **inhibitory connection** causes it to **subtract**.

44

### Intra-layer connection (**On-center/off surround**)

- A neuron within a layer has **excitatory connections** to itself
- Its immediate **neighbors**, has **inhibitory connections** to other neurons.

45

### Intra-layer connection (**On-center/off surround**)

- One can imagine this type of connection as a **competitive gang of neurons**.
- Each gang **excites itself and its gang members** and **inhibits all members of other gangs**.
- After a few rounds of signal interchange, **the neurons with an active output value will win**, and is allowed to **update its and its gang member's weights**.

46